

1.0 DIMENSIONAL DRAWING

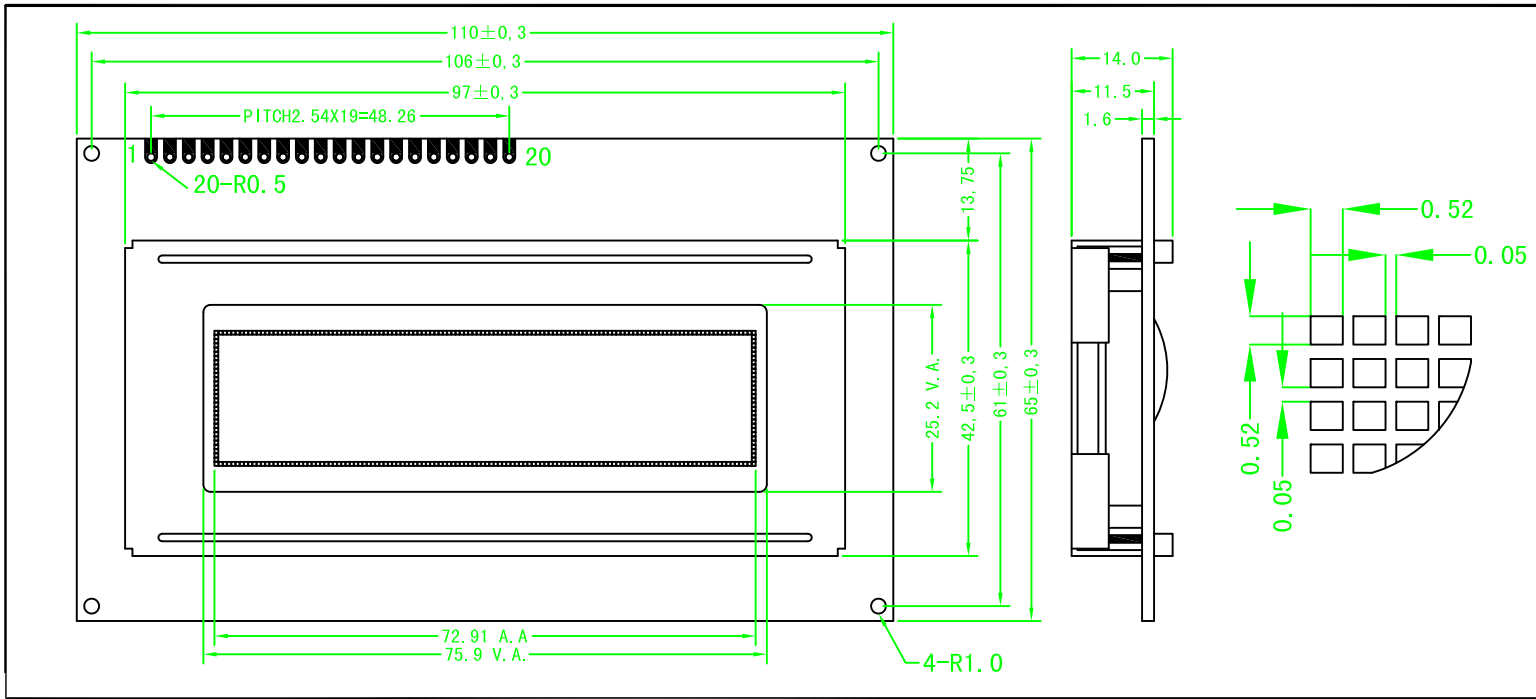

2.0 BLOCK DIAGRAM & POWER SUPPLY

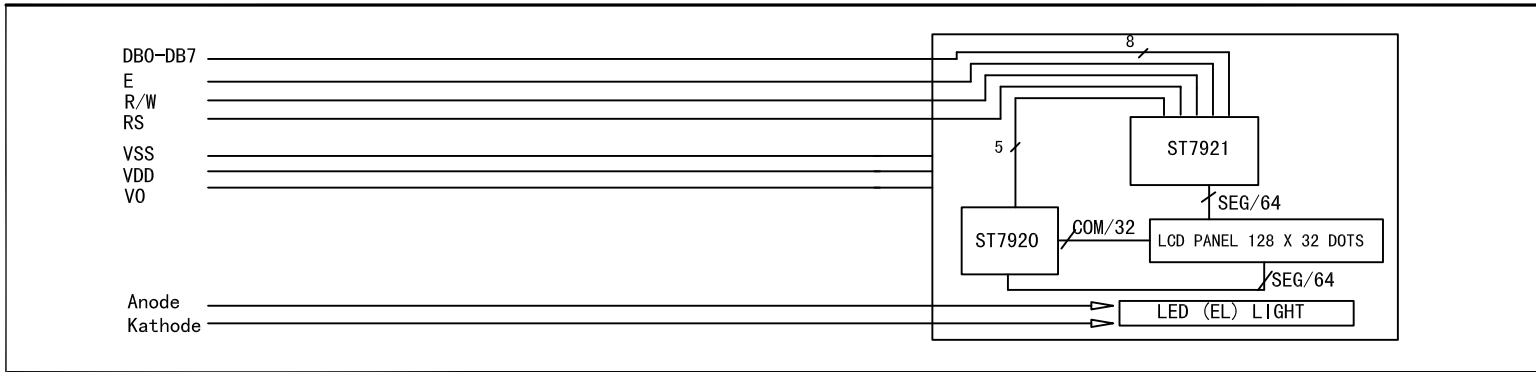

3.0 MECHANICAL SPECIFICATIONS & FEATURE

Item	Nominal Dimensions (mm)	Feature	
		LCD Type	STN
Module Size (W*H*T)	110.0 × 65.0 × 14.0	LCD Colure	Yellow-green
View Area (W*H)	75.9 × 25.2	View Angle	6 0' clock
Dot × Dot (W*H)	128 × 32	Display Type	Positive Type
Dot Pitch (W*H)	0.57 × 0.57	Rear Polarizer	Transflective
Dot Size (W*H)	0.52 × 0.52	Operating Temperature	0° C to +50° C
---	---	Storage Temperature	-10° C to +60° C
---	---	Backlight	LED (green)

4.0 ELECTRICAL CHARACTERISTICS

Item	Symbol	Test Condition	Min.	Typ.	Max.	Unit
Operating Voltage	Vdd	Ta=25° C	---	5.0	---	V
Operating Voltage For LCD	Vlcd	Ta=25° C	---	5.0	---	V
Supply Current	Idd	Ta=25° C, Vdd=3.0V	---	15	---	μA
Supply Current For Backlight	If	Ta=25° C, VAK=3.0V	---	15	---	mA

5.0 INTERFACE PIN CONNECTIONS

Pin No.	Symbol	Level	Description
1	VSS	0V	LCM Power Supply Negative Input Terminal
2	VDD	5.0V	LCM Power Supply Positive Input Terminal
3	NC		
4	RS (CS)	H/L	LCM Comand/data Input Terminal
5	R/W (SID)	H/L	LCM Read/Write Signal Input Terminal
6	E (SCLK)	H \bar{L} F	LCM Enable Signal Input Terminal
7-14	DB0-DB7	TRI-STATE	LCM 8-bits Data Input Terminal
15	PSB	H/L	LCM Parallel/serial Mode Selection Input Terminal
16	NC		
17	/RES	H→L, H	LCM Reset Signal Input Terminal
18	NC		Not Connected
19	A	5.0V	LED Backlight Power Supply Positive Input Terminal
20	K	0V	LED Backlight Power Supply Negative Input Terminal